



STANDARD EQUIPMENT

- Available power options: Bi-energy (Diesel + AC), Eco (AC+Battery)
- CANBUS electronics
- Hydraulic steering and transmission on rubber tracks
- Hydraulic set-up with 4 independent outriggers, of the fixed type
- 2 aluminium made articulated booms
- Safe working load 200 kg
- Aluminium cage 140x70x110 cm, with automatic self-levelling and hydraulic rotator 90° + 90°, equipped with support of fast disassembling for narrow passages
- Boom slewing under any condition of load and set-up at 360°
- Electric and proportional controls on dual panel: cage panel and ground panel
- 230VAC electric plug on the cage
- CE Mark homologation certificates, manuals, stickers and spares book in English language



RETURN TO HOME

The “return to home” function allows to automatically return to the transport position by pressing a button on the controls.

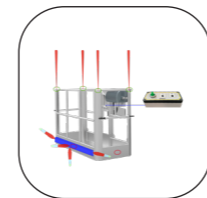

BASKET ANTI-COLLISION KIT

The laser sensors monitor the distance between the operator and any vertical obstacle, while ultrasonic sensors check the presence of any obstacles around the perimeter of the basket.

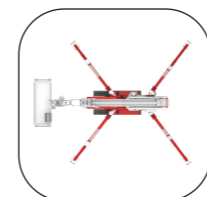

AUTOMATIC LEVELLING SYSTEM

Allows the levelling of the chassis automatically even on important slopes, allowing spider placement on roads and irregular grounds, or stairs.



NON-MARKING TRACKS

White rubber, ideal to operate indoor and/ or on delicate floors.



PEDAL ON THE CAGE

Safety pedal to operate the movements from the cage.



ADDITIONAL AIR/WATER PIPES

Extra-large diameter compressed air/water pipe to the basket.



KIT 2 SPEEDS

Increased transfer speed kit up to 2.4 km/h to be used for translation.

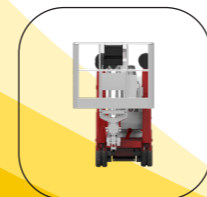

LOAD CELL

Device that monitors the basket weight, adjusting performance for safety and efficiency.



KIT PALCONNECT

Remote connection service with the aerial platform that allows the user to monitor the key parameters of use of the machine and intervene with some of them.

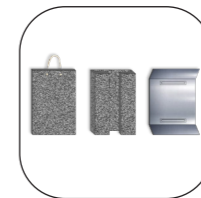

ADDITIONAL PLATES

Additional plates to distribute the load of the stabilizers on the ground and have greater stability of the machine.



CUSTOMIZED COLOURS

Possibility to customize the colours of the tracked lift with different RAL according to the client's corporate livery.



LED LIGHT

One or more additional led headlights installed on the basket or on the boom.



RADIO CONTROL

Circuit of radio-wave driven controls, for ground operation even at a great distance.



ANEMOMETER

Device for measuring the wind, with an acoustic warning of the wind max speed allowed for aerial working.



INTERCOM CIRCUIT

Electronic device for voice communication between the operator at height in the basket and the operator on the ground.





CAGE FOR ONE MAN

Alluminium cage 70x70x110 cm for one man, designed for precision tasks in tight or restricted spaces.





BI-ENERGY

 Diesel
10,6 kW

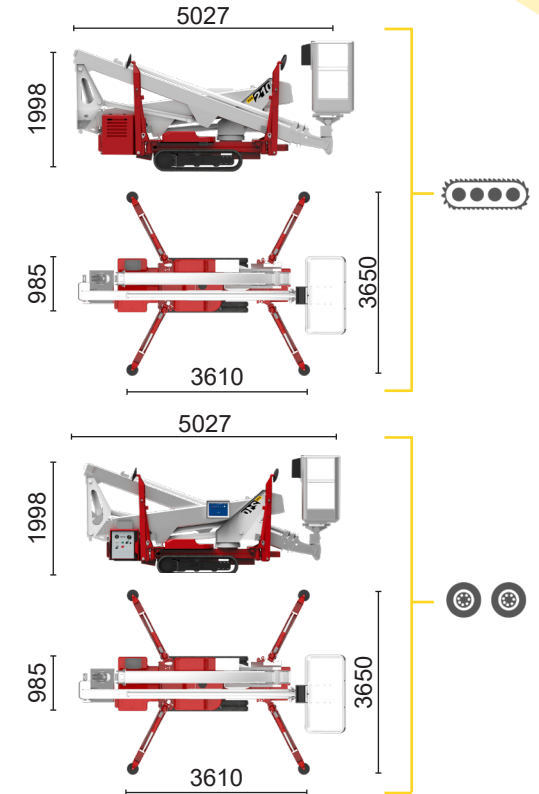
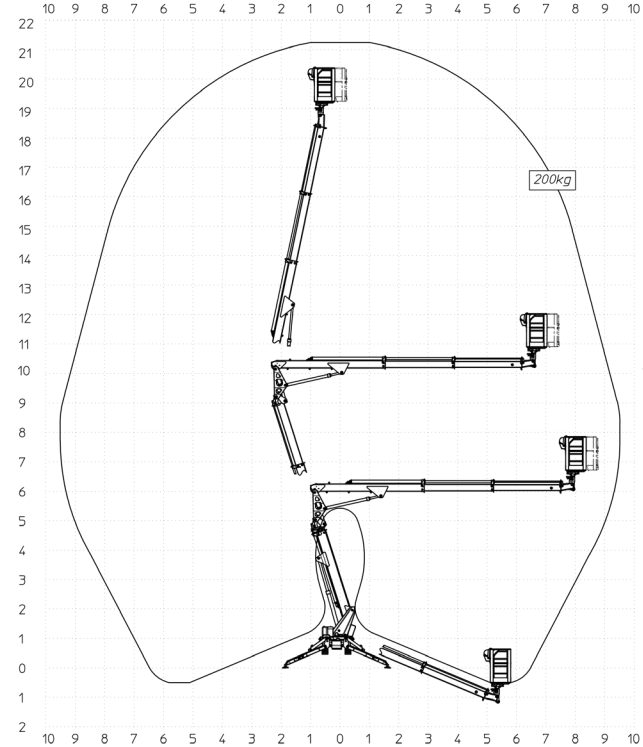
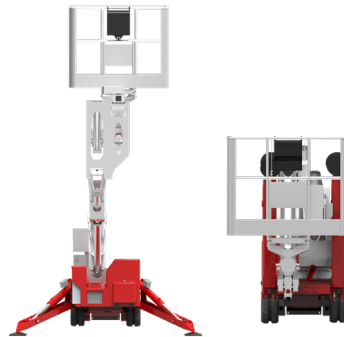
 Single-phase
Electric motor
230 VAC - 2,5 kW



TZX 210/C		21,2 m	9,5 m	200 kg	360°	140x70 cm	90°+90°	3,65 m	21%	23%	2 km/h	2500 kg	19 kN	1,9 kN/m ²	3,55 kN/m ²
TZX 210/R		21,2 m	9,5 m	200 kg	360°	140x70 cm	90°+90°	3,65 m	21%	23%	2 km/h	2500 kg	19 kN	1,9 kN/m ²	3,55 kN/m ²

Available power options:
ECO (AC+BATTERY)

The technical data may deviate +/- 3% from the specified values.
Characteristics and technical data are informative only and subjected to change without notice.

Palazzani Industrie S.p.A.
Via del Pavione, 4 - 25050 - Paderno F.C. (BS) - Italy
Tel. (+39) 0306857073
info@palazzani.it
www.palazzani.it







ECO

 Inverter actuated Electric motor

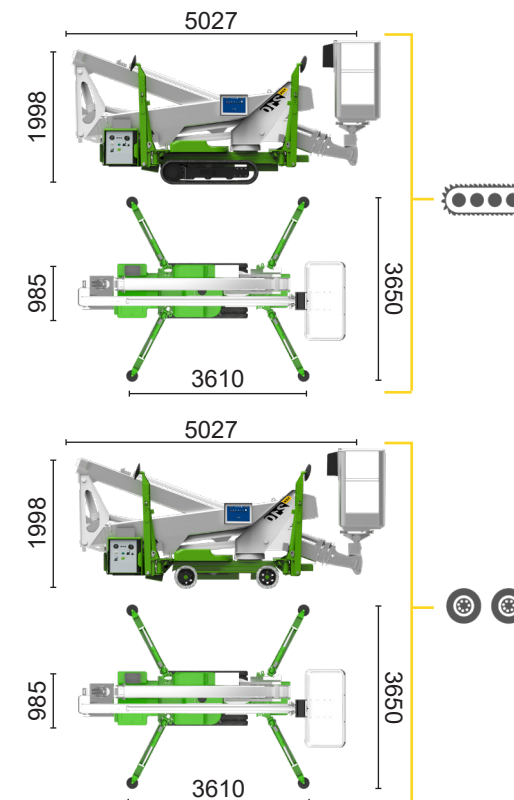
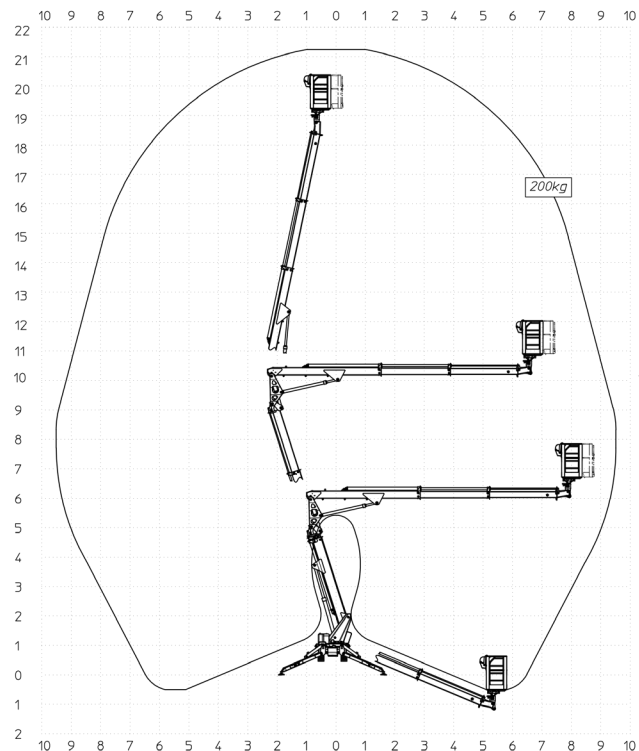
 Lithium iron phosphate battery LiFePO4



TZX 210/C		21,2 m	9,5 m	200 kg	360°	140x70 cm	90°+90°	3,65 m	21%	23%	2 km/h	2500 kg	19 kN	1,9 kN/m2	3,55 kN/m2
TZX 210/R		21,2 m	9,5 m	200 kg	360°	140x70 cm	90°+90°	3,65 m	21%	23%	2 km/h	2500 kg	19 kN	1,9 kN/m2	3,55 kN/m2

Available power options:

 **BI-ENERGY** (DIESEL+AC)

The technical data may deviate +/- 3% from the specified values.

Characteristics and technical data are informative only and subjected to change without notice.

Palazzani Industrie S.p.A.

Via del Pavione, 4 - 25050 - Paderno F.C. (BS) - Italy

Tel. (+39) 0306857073

info@palazzani.it

www.palazzani.it

