

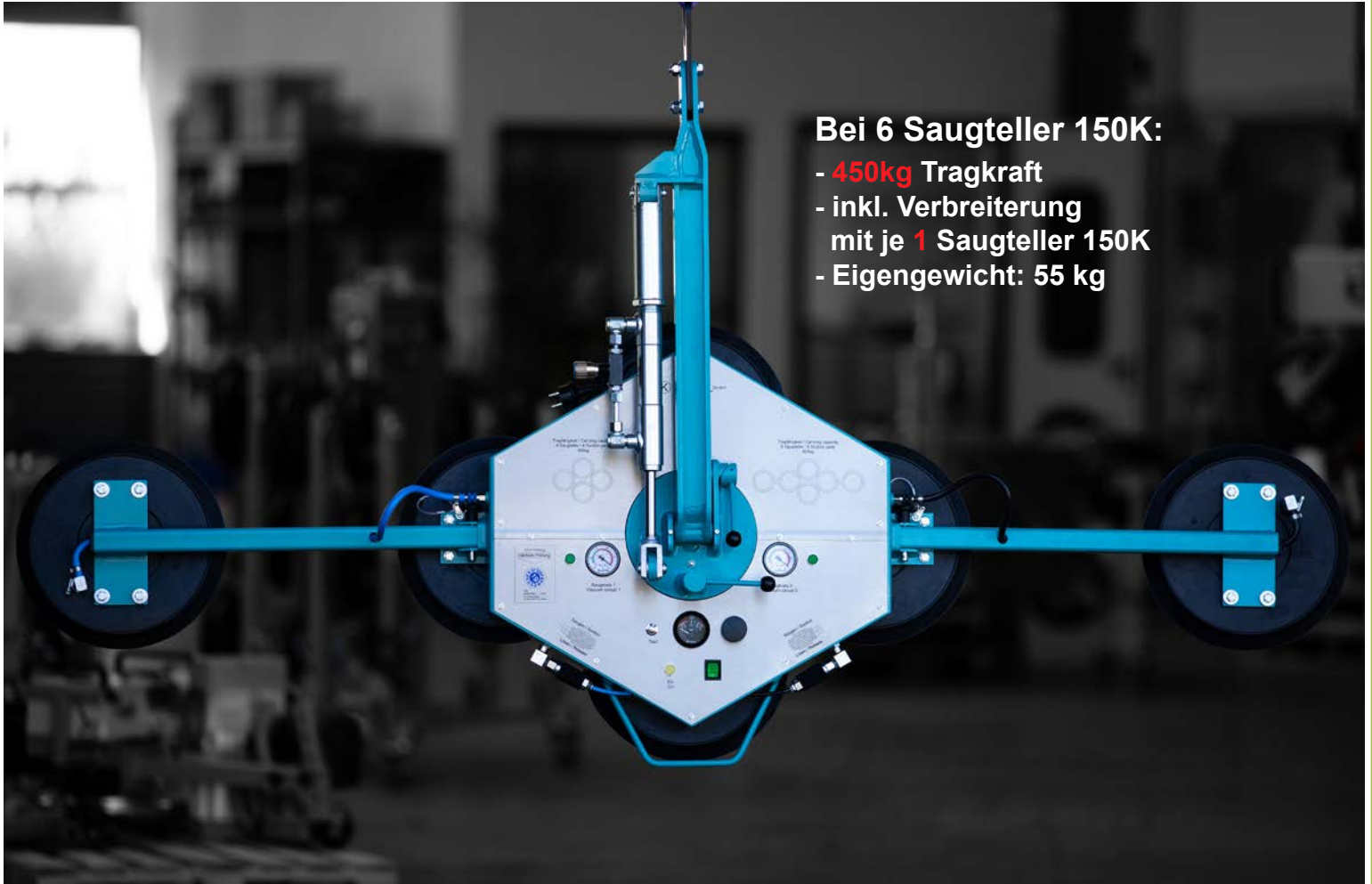

DSKZL2 - 12V

nach EN13155 / max. 450 kg Tragkraft



Bei 6 Saugteller 150K:

- **450kg** Tragkraft
- inkl. Verbreiterung mit je **1** Saugteller 150K
- Eigengewicht: 55 kg

Technische Daten:

- 12 V Batteriebetrieb
- Zweikreissauganlage
- Warneinrichtung
- Vakuumtank
- Spannungsanzeige
- Ladegerät
- Manuell Drehen 360°
- Manuell Kippen 90°

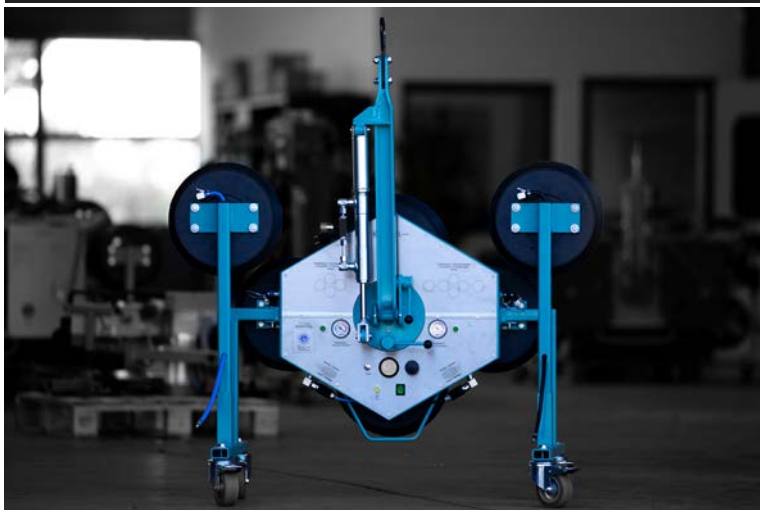

Bei 4 Saugteller 150K:

- **300kg** Tragkraft
- Eigengewicht: 50 kg



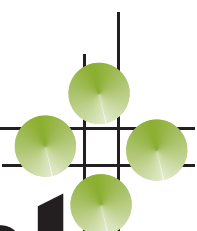
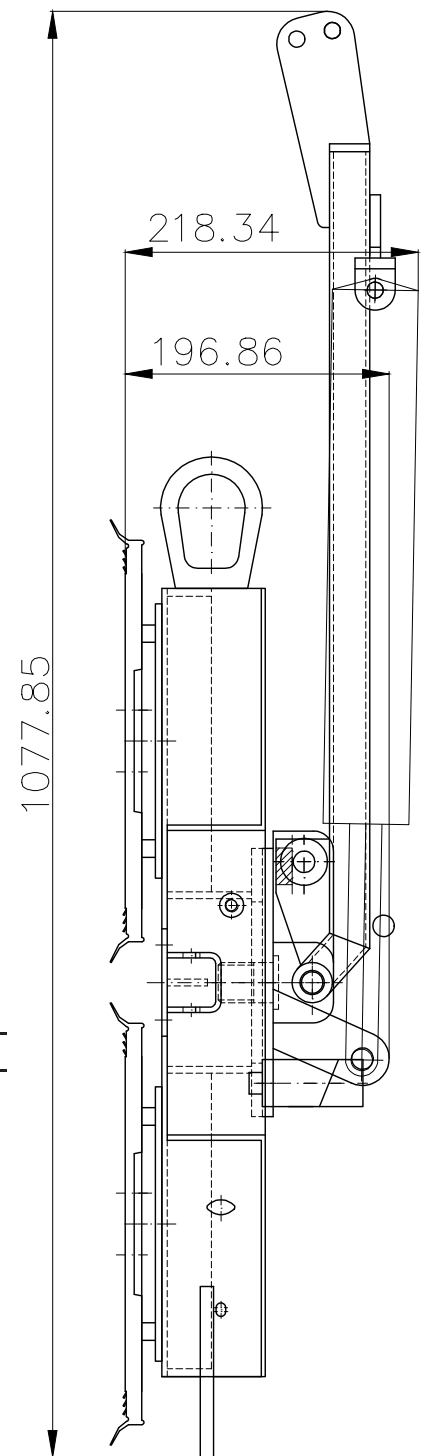
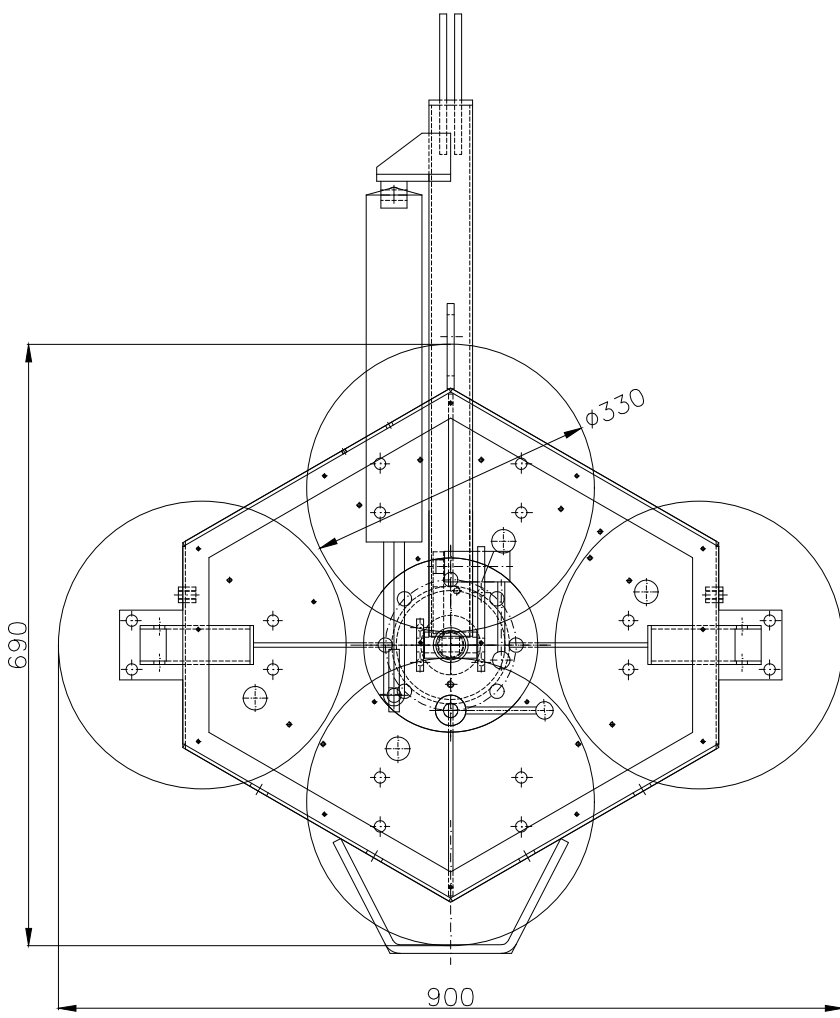

Robert
Kappel
 GmbH

